



REV.	ECN NO.	REVISED	DATE

1.MATERIAL:

- a.HOUSING:PPS UL94V-0
- b.CONTACT:PHOSPHOR BRONZE  
(SURFACE PLATING: Au1u")

SEE ORDERING INFORMATION

2.ELECTRIC:

- a.CONTACT RESISTANCE: 30 MILLIOHMS MAX
- b.INSULATION RESISTANCE: 100 MEGA OHMS MIN
- c.DIELECTNIC VOLTAGE: 500V AC ONE SEC LEVEL
- d.OPERATING TEMPERATURE: -25°C~ +85°C

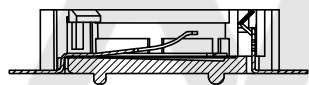
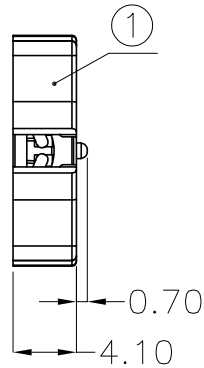
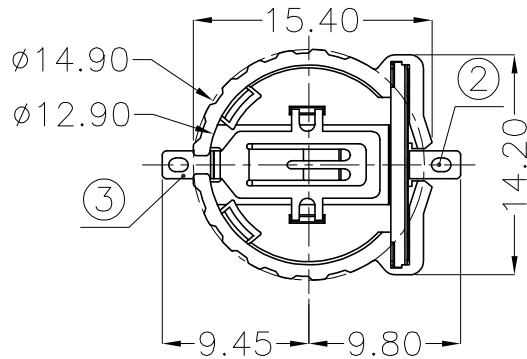

ORDERING INFORMATION

BS-12-B\*\*\*007

电池座系列

BS-12系列

SMT 180° TYPE

PLATING:  
A-Au1U"  
J-Ni100U"~120U"  
K-Sn100U"~120U"

MATERIAL:  
1A-PBT BLACK  
1B-PA66 BLACK  
2A-PPA BROWN  
2B-PPA BLACK  
3A-PPS BROWN  
3B-PPS BLACK  
4A-LCP WHITE  
4B-LCP BLACK

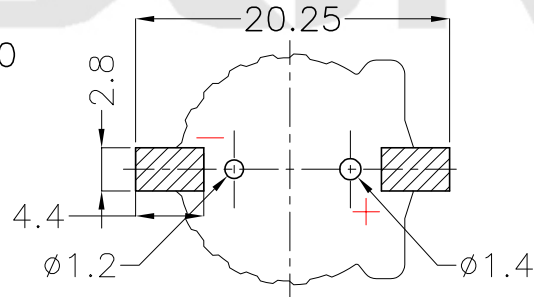
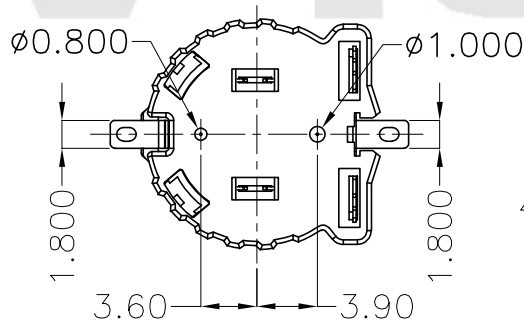

PCB Layout Diagram  
Top View

工程部  
2017-06-28  
ZW DANG

UNLESS OTHERWISE SPECIFIED TOLERANCES		<b>MYOUNG 美阳</b> <a href="http://www.meiyangdz.com">www.meiyangdz.com</a>	
DECIMALS: X :±0.30 X.X :±0.25 X.XX :±0.20 X.XXX :±0.10	ANGLES: X :±1° X.X :±0.5°	DSND YangFeng	DATE 2017-06-28
		CHKD ZhouRuicai	DATE 2017-06-28
		APVD XueShun Yong	DATE 2017-06-28
WEIGHT: 0.67g		SCALE: 2:1	SIZE: A4
SHEET 1 OF 1		VIEW:	
		UNIT: mm	REV.: A/0
		OBJECT: MY	DRAW NO.:MY-CP-0058
		TITLE: BS-1220-2K PPS SMT	
		PART NO.: BS-12-B3AA007	

3	TERMINAL(-)	1	PHOSPHOR BRONZE, T=0.20mm	Gold Plating and Ni Under-Plating
2	TERMINAL(+)	1	PHOSPHOR BRONZE, T=0.20mm	Gold Plating and Ni Under-Plating
1	HOUSING	1	PPS	BROWN
NO.	PART NAME	Q'TY	MATERIAL	PLATING & COLOR