



REV.	ECN NO.	REVISED	DATE

NOTE:

1.MATERIAL:

- a.HOUSING:PPA
- b.CONTACT:PHOSPHOR BRONZE
(SURFACE PLATING: Au1u")

SEE ORDERING INFORMATION

2.ELECTRIC:

- a.CONTACT RESISTANCE: 30 MILLIOHMS MAX
- b.INSULATION RESISTANCE: 100 MEGA OHMS MIN
- c.DIELECTNIC VOLTAGE: 500V AC ONE SEC LEVEL
- d.OPERATING TEMPERATURE: -25° C~ +85° C

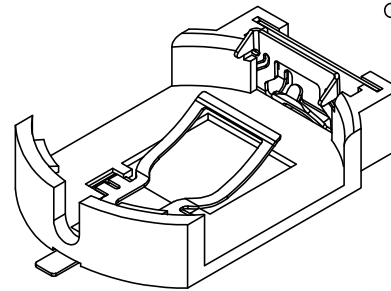
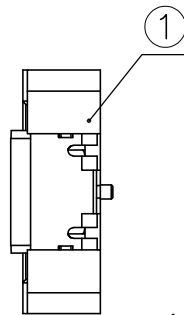
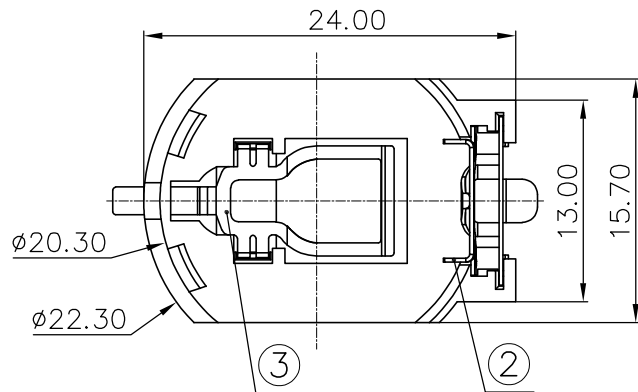

ORDERING INFORMATION

BS-08-B2BA030

电池座系列

BS-08系列

SMT 180° TYPE

PLATING:
A-Au1U"
J-Ni100U"~120U"
K-Sn100U"~120U"

MATERIAL:
1A-PBT BLACK
1B-PA66 BLACK
2A-PPA BROWN
2B-PPA BLACK
3A-PPS BROWN
3B-PPS BLACK
4A-LCP WHITE
4B-LCP BLACK

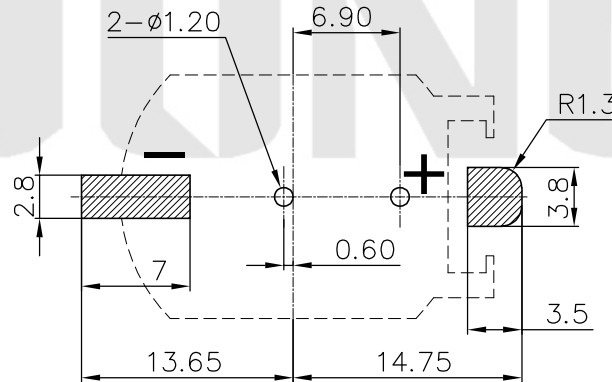
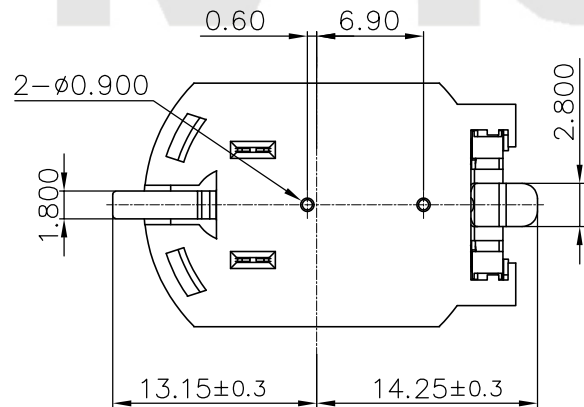
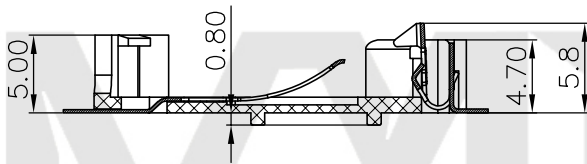

PCB Layout Diagram
Top View

工程部

2021-06-11

LQ. HUANG

UNLESS OTHERWISE SPECIFIED TOLERANCES

DECIMALS: X :±0.30 X.X :±0.25 X.XX :±0.20 X.XXX :±0.10
ANGLES: X :±1° X.X :±0.5°

MYOUNG 美阳 www.meiyangdz.com

DSND	YangFeng	DATE	2021-06-11
CHKD	ZhouRuicai	DATE	2021-06-11
APVD	XueShunyong	DATE	2021-06-11

TITLE:
BS-2032-8CGZ2.0 5MM SMT

PART NO.:
BS-08-8CGZ-B2BA030

3	TERMINAL(-)	1	PHOSPHOR BRONZE, T=0.20mm	Gold Plating and Ni Under-Plating
2	TERMINAL(+)	1	PHOSPHOR BRONZE, T=0.25mm	Gold Plating and Ni Under-Plating
1	HOUSING	1	PPA	BLACK
NO.	PART NAME	Q'TY	MATERIAL	PLATING & COLOR

WEIGHT: 9
SHEET 1 OF 1

SCALE: VIEW:
UNIT: mm REV.: A/0 OBJECT: MY

DRAW NO.:MY-CP-0167