

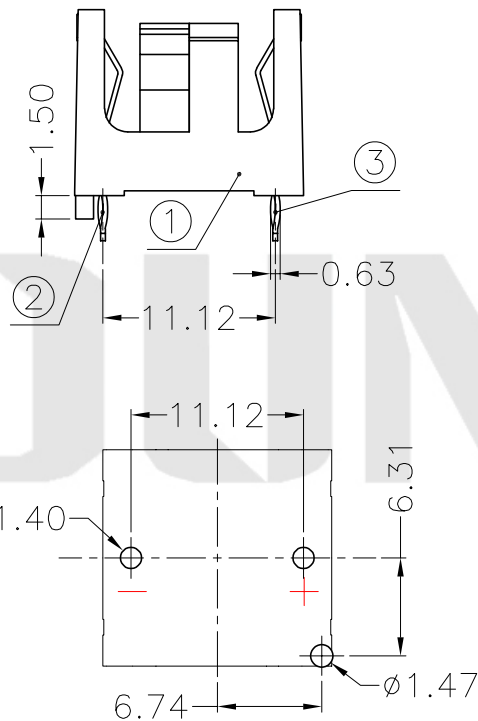

REV.	ECN NO.	REVISED	DATE

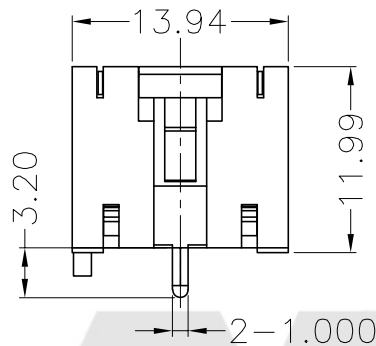
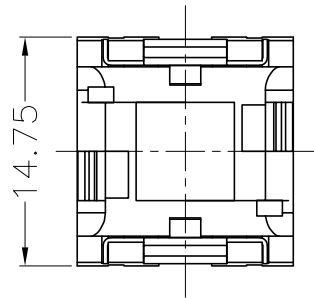

PCB Layout Diagram  
Top View

1.MATERIAL:

- a.HOUSING:PPA
- b.CONTACT:PHOSPHOR BRONZE  
(SURFACE PLATING: Au1u")

SEE ORDERING INFORMATION

2.ELECTRIC:

- a.CONTACT RESISTANCE: 30 MILLIOHMS MAX
- b.INSULATION RESISTANCE: 100 MEGA OHMS MIN
- c.DIELECTNIC VOLTAGE: 500V AC ONE SEC LEVEL
- d.OPERATING TEMPERATURE: -25°C~ +85°C

ORDERING INFORMATION

BS-09-A\*\*\*002

电池座系列

BS-09系列

DIP 90° TYPE

PLATING:  
A-Au1U"  
J-Ni100U"~120U"  
K-Sn100U"~120U"

MATERIAL:  
1A-PBT BLACK  
1B-PA66 BLACK  
2A-PPA BROWN  
2B-PPA BLACK  
3A-PPS BROWN  
3B-PPS BLACK  
4A-LCP WHITE  
4B-LCP BLACK



3	TERMINAL(-)	1	PHOSPHOR BRONZE, T=0.30mm	Gold Plating and Ni Under-Plating
2	TERMINAL(+)	1	PHOSPHOR BRONZE, T=0.30mm	Gold Plating and Ni Under-Plating
1	HOUSING	1	PPA	BLACK
NO.	PART NAME	Q'TY	MATERIAL	PLATING & COLOR

UNLESS OTHERWISE SPECIFIED TOLERANCES		<b>MYOUNG 美阳</b> <a href="http://www.meiyangdz.com">www.meiyangdz.com</a>			
DECIMALS: X :±0.30 X.X :±0.25 X.XX :±0.20 X.XXX :±0.10	ANGLES: X :±1° X.X :±0.5°	DSND	YangFeng	DATE	2017-07-13
		CHKD	ZhouRuicai	DATE	2017-07-13
		APVD	XueShunyong	DATE	2017-07-13
WEIGHT: 1.91g		SCALE: 2:1		SIZE: A4	VIEW:
SHEET 1 OF 1		UNIT: mm	REV.: A/0	OBJECT: MY	DRAW NO.:MY-CP-0084

TITLE:  
BS-2AG13-9 DIP

PART NO.:  
BS-09-A2BA002