

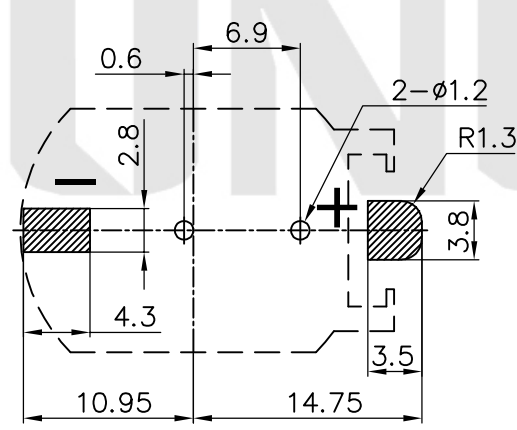

REV.	ECN NO.	REVISED	DATE

NOTE:
 1.MATERIAL:
 a.HOUSING:PPA
 b.CONTACT:PHOSPHOR BRONZE
 (SURFACE PLATING: Au1u")
 SEE ORDERING INFORMATION
 2.ELECTRIC:
 a.CONTACT RESISTANCE: 30 MILLIOHMS MAX
 b.INSULATION RESISTANCE: 100 MEGA OHMS MIN
 c.DIELECTNIC VOLTAGE: 500V AC ONE SEC LEVEL
 d.OPERATING TEMPERATURE: -25° C~ +85° C

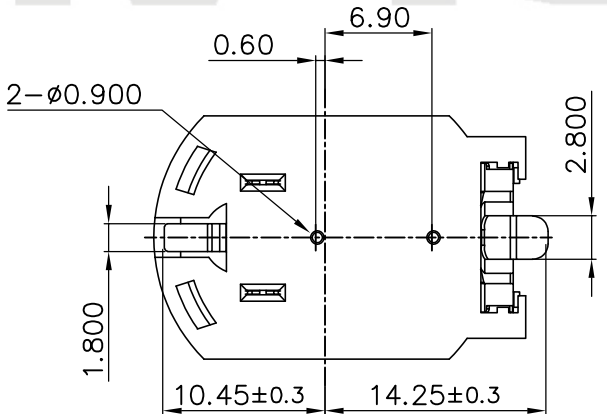
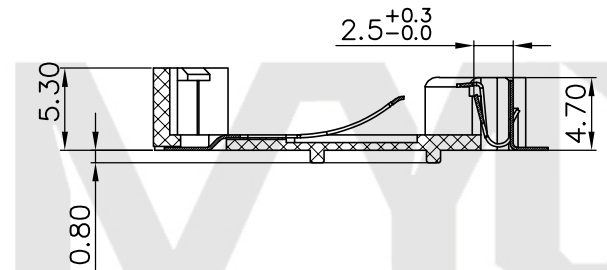
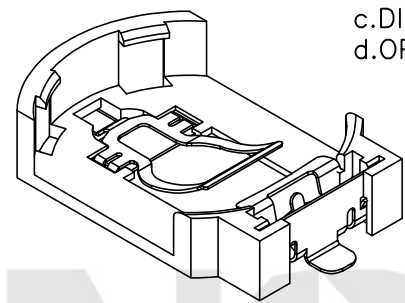
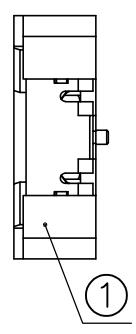
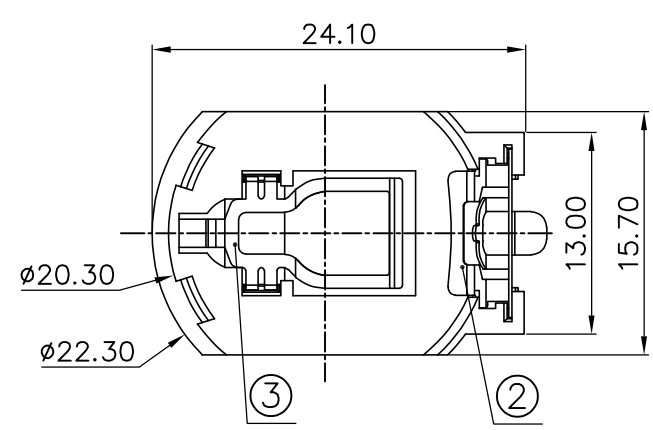

PCB Layout Diagram
Top View

ORDERING INFORMATION
BS-08-B2AA025

PLATING:
 A-Au1U"
 J-Ni100U"~120U"
 K-Sn100U"~120U"
 MATERIAL:
 1A-PBT BLACK
 1B-PA66 BLACK
 2A-PPA BROWN
 2B-PPA BLACK
 3A-PPS BROWN
 3B-PPS BLACK
 4A-LCP WHITE
 4B-LCP BLACK

电池座系列
 BS-08系列
 SMT 180° TYPE



3	TERMINAL(-)	1	PHOSPHOR BRONZE, T=0.20mm	Gold Plating and Ni Under-Plating
2	TERMINAL(+)	1	PHOSPHOR BRONZE, T=0.20mm	Gold Plating and Ni Under-Plating
1	HOUSING	1	PPA	BROWN
NO.	PART NAME	Q'TY	MATERIAL	PLATING & COLOR

UNLESS OTHERWISE SPECIFIED TOLERANCES		MYOUNG 美阳 www.meiyangdz.com	
DECIMALS: X :±0.30 X.X :±0.25 X.XX :±0.20 X.XXX :±0.10	ANGLES: X :±1° X.X :±0.5°	DSND YangFeng	DATE 2021-06-01
WEIGHT: 9		CHKD ZhouRuicai	DATE 2021-06-01
SHEET 1 OF 1		APVD XueShunyang	DATE 2021-06-01
SCALE: UNIT: mm	SIZE: A4	VIEW:	TITLE: BS-2032-8Z SMT
REV.: A/0	OBJECT: MY	PART NO.: BS-08-B2AA025	
		DRAW NO.:MY-CP-0072	