



REV.	ECN NO.	REVISED	DATE

NOTE:

1.MATERIAL:

- a.HOUSING:PA66
- b.CONTACT:PHOSPHOR BRONZE
(SURFACE PLATING: Sn 100u"-120u")
SEE ORDERING INFORMATION

2.ELECTRIC:

- a.CONTACT RESISTANCE: 50 MILLIOHMS MAX
- b.INSULATION RESISTANCE: 100 MEGA OHMS MIN
- c.DIELECTNIC VOLTAGE: 500V AC ONE SEC LEVEL
- d.OPERATING TEMPERATURE: -25°C~ +85°C

ORDERING INFORMATION

BS-24-A***002

电池座系列

BS-24系列

DIP 90° TYPE

PLATING:
A-Au1U"
J-Ni100U"~120U"
K-Sn100U"~120U"

MATERIAL:
1A-PBT BLACK
1B-PA66 BLACK
2A-PPA BROWN
2B-PPA BLACK
3A-PPS BROWN
3B-PPS BLACK
4A-LCP WHITE
4B-LCP BLACK

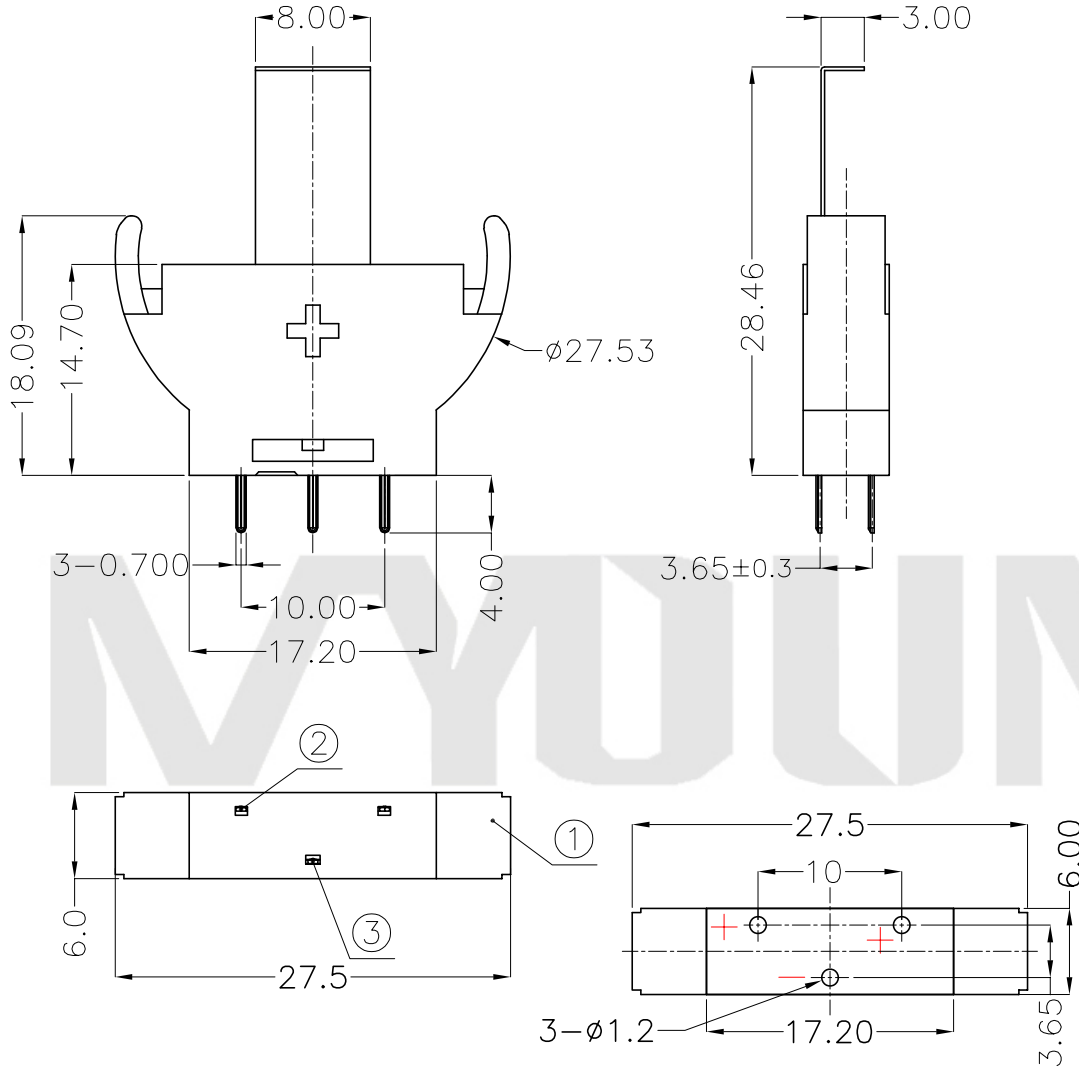

PCB Layout Diagram
Top View

NO.	PART NAME	Q'TY	MATERIAL	PLATING & COLOR
3	TERMINAL(-)	1	PHOSPHOR BRONZE,T=0.25mm	Sn Plating
2	TERMINAL(+)	1	PHOSPHOR BRONZE,T=0.25mm	Sn Plating
1	HOUSING	1	PA66	BLACK

UNLESS OTHERWISE SPECIFIED TOLERANCES		MYOUNG 美阳 www.meiyangdz.com			
DECIMALS: X :±0.30 X.X :±0.25 X.XX :±0.20 X.XXX :±0.10	ANGLES: X :±1° X.X :±0.5°	DSND	YangFeng	DATE	2017-07-16
		CHKD	ZhouRuicai	DATE	2017-07-16
		APVD	XueShun Yong	DATE	2017-07-16
WEIGHT: 2.35g		SCALE: 2:1	SIZE: A4	VIEW:	TITLE: BS-2430-2 Sn DIP
SHEET 1 OF 1		UNIT: mm	REV.: A/0	OBJECT: MY	PART NO.: BS-24-A1BK002
					DRAW NO.:MY-CP-0040