

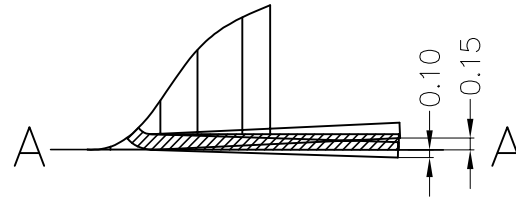

REV.	ECN NO.	REVISED	DATE

- 1.MATERIAL:
a.HOUSING:PPS UL94V-0
b.CONTACT:PHOSPHOR BRONZE
(SURFACE PLATING:AU1u")
SEE ORDERING INFORMATION

- 2.ELECTRIC:
a.CONTACT RESISTANCE: 30 MILLIOHMS MAX
b.INSULATION RESISTANCE: 100 MEGA OHMS MIN
c.DIELECTNIC VOLTAGE: 500V AC ONE SEC LEVEL
d.OPERATING TEMPERATURE: -55°C~ +85°C



Flatness of terminals

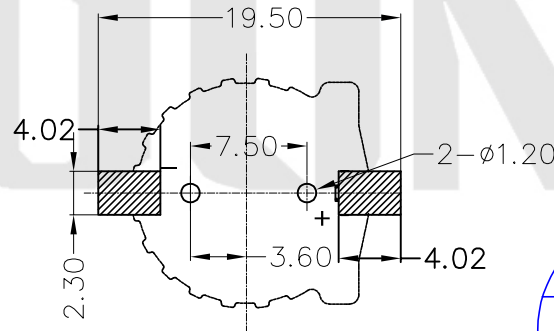
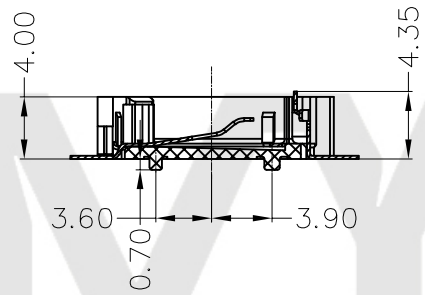
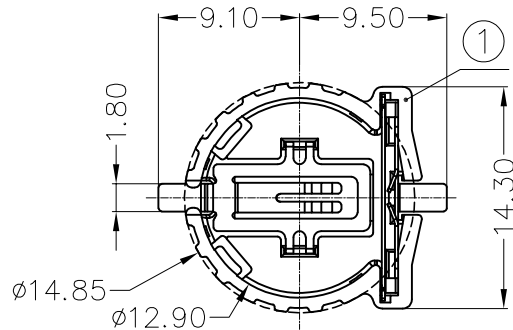

PCB Layout Diagram
Top View

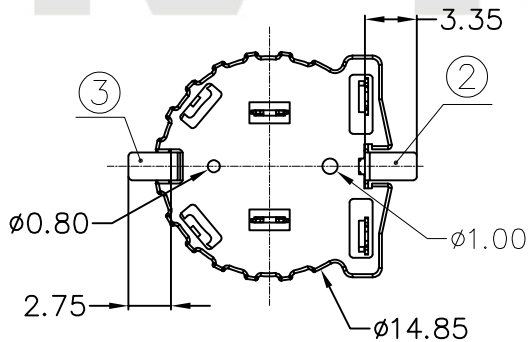

ORDERING INFORMATION
BS-12-B*013**

电池座系列

BS-12系列

SMT 180° TYPE

PLATING:
A-Au1U"
J-Ni100U"~120U"
K-Sn100U"~120U"

MATERIAL:
1A-PBT BLACK
1B-PA66 BLACK
2A-PPA BROWN
2B-PPA BLACK
3A-PPS BROWN
3B-PPS BLACK
4A-LCP WHITE
4B-LCP BLACK

工程部
2022-08-27
LQ. HUANG

UNLESS OTHERWISE SPECIFIED TOLERANCES		MYOUNG 美阳 www.meiyangdz.com	
DECIMALS: X :±0.30 X.X :±0.25 X.XX :±0.20 X.XXX :±0.10	ANGLES: X :±1° X.X :±0.5°	DSND YangFeng	DATE 2022-08-27
TITLE: BS-1225-2 PPS SMT		CHKD ZhouRuicai	DATE 2022-08-27
PART NO.:		APVD XueShunyong	DATE 2022-08-27
WEIGHT:0.63g		SCALE:2:1	SIZE: A4
SHEET 1 OF 1		VIEW:	
		UNIT: mm	REV.: A/0
		OBJECT: MY	DRAW NO.:MY-CP-0293

NO.	PART NAME	Q'TY	MATERIAL	PLATING & COLOR
3	TERMINAL(-)	1	PHOSPHOR BRONZE, T=0.20mm	Gold Plating and Ni Under-Plating
2	TERMINAL(+)	1	PHOSPHOR BRONZE, T=0.20mm	Gold Plating and Ni Under-Plating
1	HOUSING	1	PPS	BROWN