

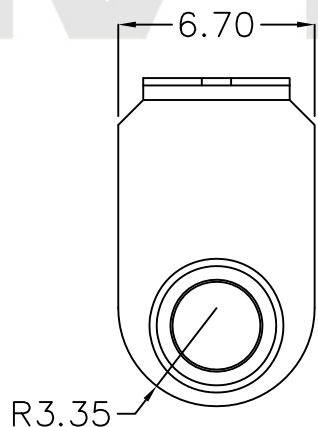

REV.	ECN NO.	REVISED	DATE

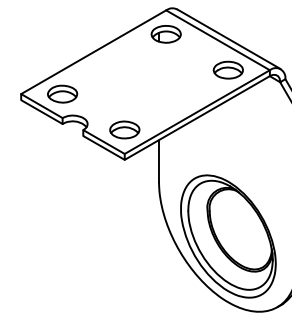
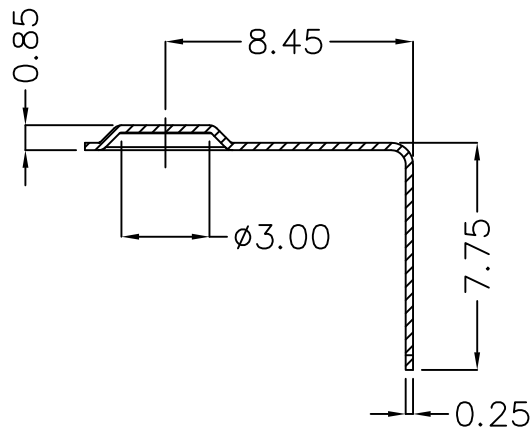
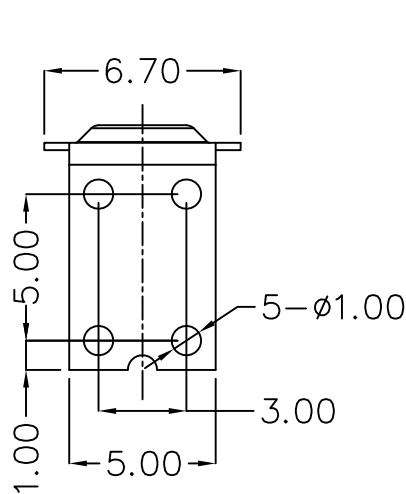

MYOUNG 美阳

工程部  
2018-10-19  
LQ. HUANG

技术要求:

- 1、截剪断面毛刺高度 $\leq 0.03\text{mm}$ ;
- 2、部件要求平整,无变形、裂纹、损伤等外观缺陷;

UNLESS OTHERWISE SPECIFIED TOLERANCES		<b>MYOUNG 美阳</b> <a href="http://www.meiyangdz.com">www.meiyangdz.com</a>			
DECIMALS: X :±0.30 X.X :±0.25 X.XX :±0.20 X.XXX :±0.10	ANGLES: X :±1° X.X :±0.5°	DSND	YangFeng	DATE	2018-06-13
		CHKD	ZhouRuicai	DATE	2018-06-13
		APVD	XueShunyong	DATE	2018-06-13
WEIGHT:		SCALE:	SIZE: A4	VIEW:	
SHEET 1 OF 1		UNIT: mm	REV.: A/0	OBJECT: MY	TITLE: 电池弹片3030
					PART NO.: MY-ZJ-3030
					DRAW NO.:MY-CP-0110

1	TERMINAL(+)	1	Mn STEEL T=0.25	Tin Nickel
NO.	PART NAME	Q'TY	MATERIAL	PLATING & COLOR

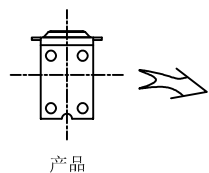

产品

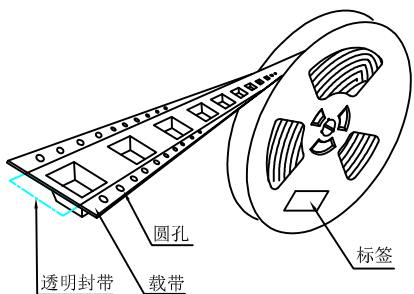

圆孔

透明封带

载带

标签

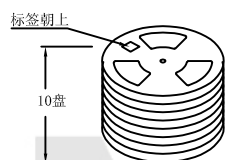

标签朝上

10盘

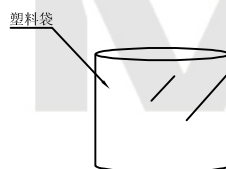

塑料袋

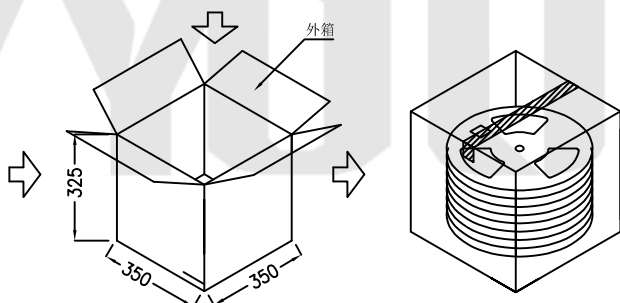

外箱

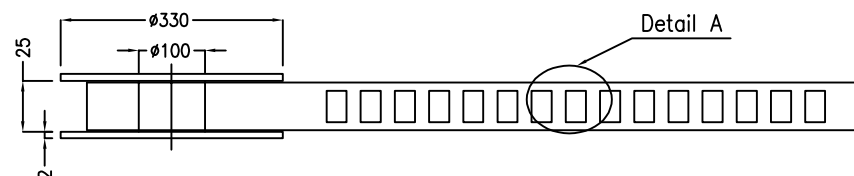

Detail A

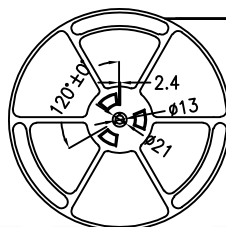

出料方向

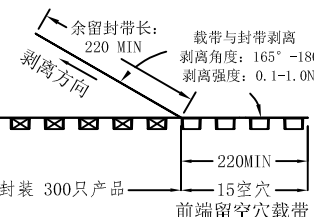

剥离方向

载带与封带剥离  
剥离角度: 165°-180°  
剥离强度: 0.1-1.0N

共封装 300只产品  
前端留空穴载带  
末端留空穴载带

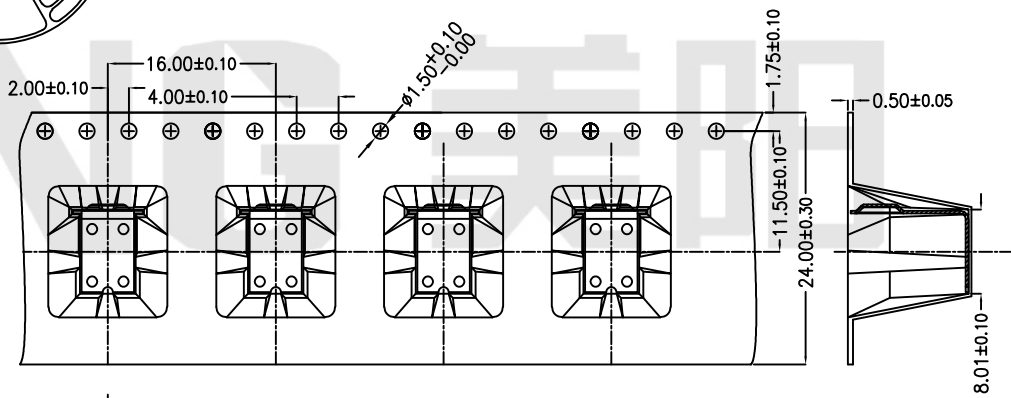

Detail A

技术要求:

1. 圆孔十个孔距离累计允许公差为±0.2mm
2. 带长250mm内容许弯曲度1mm
3. 材料厚度以在载带边缘测量为准
4. 所有尺寸定义依循EIA-481-C系准则定义之
5. 材料: 黑色PS T=0.50±0.05mm
6. 所有卷轮为灰蓝挖空旋转塑胶卷轮
7. 整模成型长度: 5.28M,
8. 非指明公差范围为: ±0.1mm; 超过250mm不计算累计误差
9. 型腔外形凡未标明处倒角R为0.2-0.3; 拔模斜度未标注的为3° 以下

包装信息:

- 1、每卷盘装产品 300 只, 卷盘外侧贴相关标签;
- 2、每 10 卷盘放在一个塑料袋中;
- 3、每外箱装10盘, 产品总数: 3000 只;
- 4、外箱上下用胶纸封成“工”字;
- 5、净重: KG, 毛重: KG。



UNLESS OTHERWISE SPECIFIED TOLERANCES		<b>MYOUNG 美阳</b> www.meiyangdz.com			
DECIMALS: X : ±*** X.X : ±*** X.XX : ±*** X.XXX : ±***	ANGLES: X : ±*** X.X : ±***	DSND YangFeng	DATE 2021-09-15	TITLE: 电池弹片PPBA3030 SMT 卷装	
		CHKD ZhouRuicai	DATE 2021-09-15	PART NO.:	
		APVD XueShun Yong	DATE 2021-09-15	MY-ZJ-3030-R	
WEIGHT:		SCALE: 3:1	SIZE: A4	VIEW:	
SHEET 1 OF 1		UNIT: mm	REV.: A/0	OBJECT: MY	DRAW NO.: MY-BD-0029