

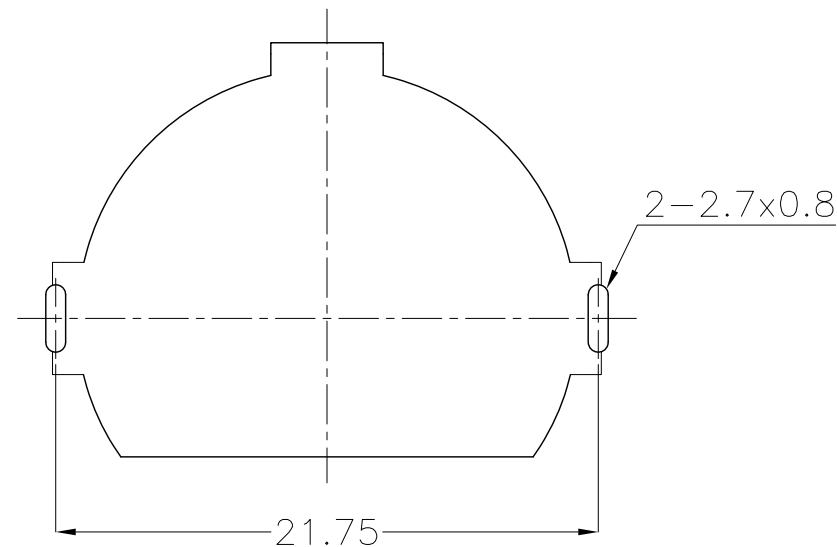

REV.	ECN NO.	REVISED	DATE

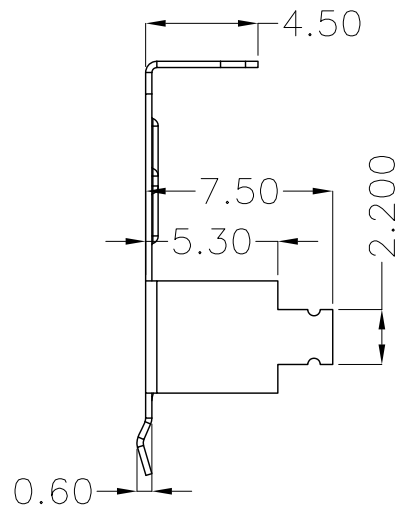

PCB Layout Diagram
Top View

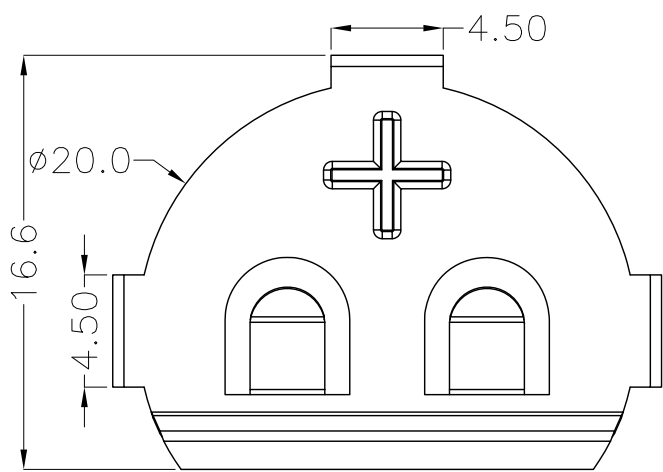
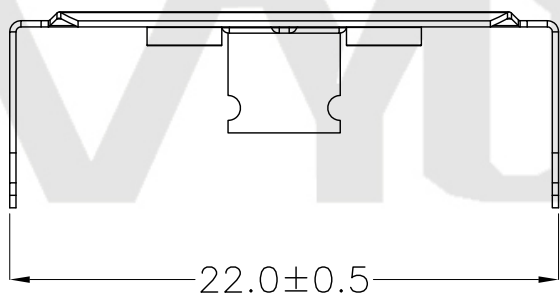

工程部
2018-10-26
LQ. HUANG

UNLESS OTHERWISE SPECIFIED TOLERANCES		MYOUNG 美阳 www.meiyangdz.com			
DECIMALS: X :±0.30 X.X :±0.25 X.XX :±0.20 X.XXX :±0.10	ANGLES: X :±1° X.X :±0.5°	DSND	YangFeng	DATE	2018-10-26
WEIGHT: g		CHKD	ZhouRuicai	DATE	2018-10-26
SHEET 1 OF 1		APVD	XueShunyong	DATE	2018-10-26
TITLE:		SCALE:	4:1	SIZE:	A4
PART NO.:		VIEW:	⊙ ←	UNIT:	mm
DRAW NO.:MY-CP-0159		REV.:	A/0	OBJECT:	MY

1	TERMINAL(+)	1	PHOSPHOR BRONZE, T=0.25mm	Ni-Plating
NO.	PART NAME	Q'TY	MATERIAL	PLATING & COLOR



产品

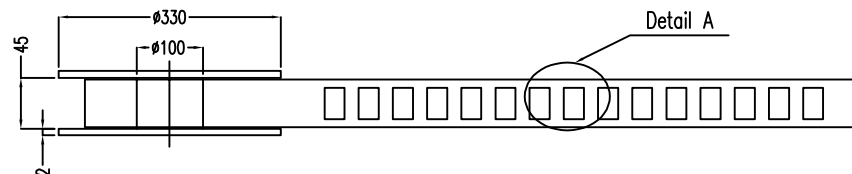
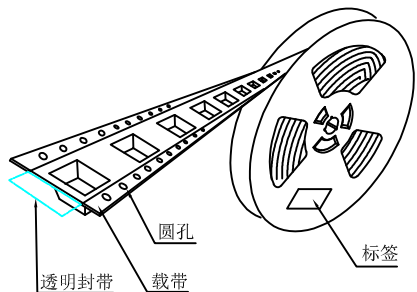

Detail A

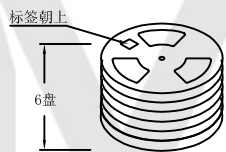
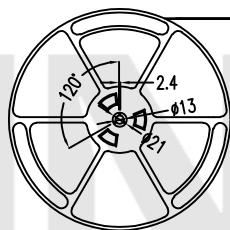
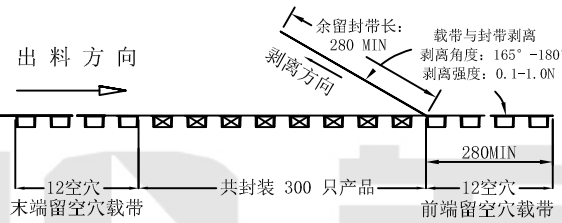

6盘

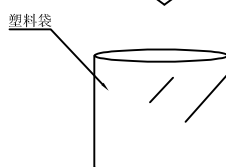

塑料袋

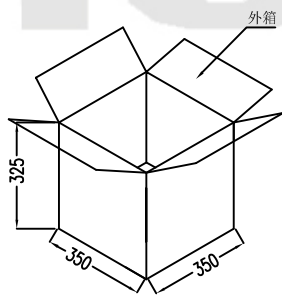

外箱

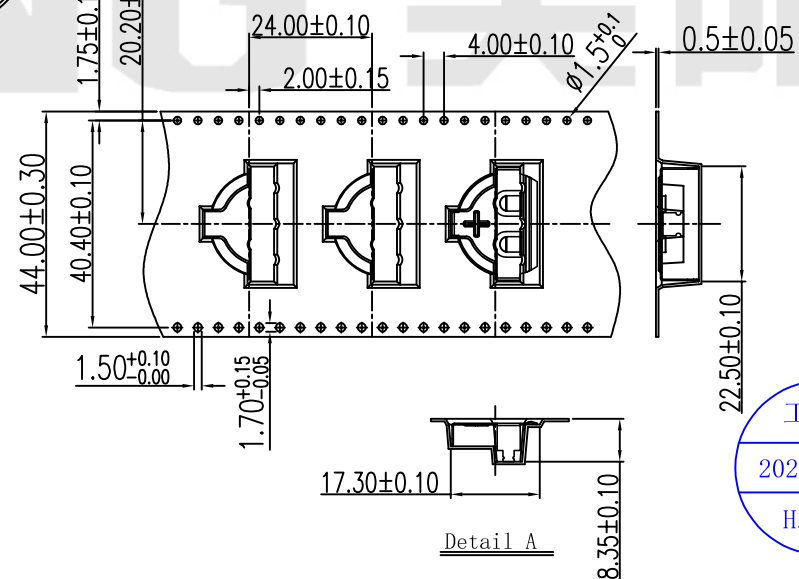
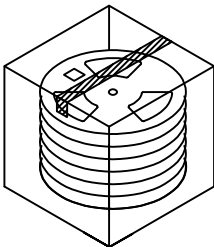

Detail A

- 技术要求:
1. 圆孔十个孔距离累计允许公差为±0.2mm
 2. 带长250mm内容许弯曲度1mm
 3. 材料厚度以在载带边缘测量为准
 4. 所有尺寸定义依循EIA-481-C系准则定义之
 5. 材料: 黑色PS T=0.5mm
 6. 所有卷轮为灰蓝挖空旋转塑胶卷轮
 7. 整模成型长度: 7.776M,
 8. 非指明公差范围为: ±0.1mm; 超过250mm不计算累计误差
 9. 型腔外形凡未标明处倒角R为0.2-0.3; 拔模斜度未标注的为3° 以下

- 包装信息:
- 1、每卷盘装产品 300 只, 卷盘外侧贴相关标签;
 - 2、每 6 卷盘放在一个塑料袋中;
 - 3、每外箱装6盘, 产品总数: 1800 只;
 - 4、外箱上下用胶纸封成“工”字;
 - 5、净重: KG, 毛重: KG。



UNLESS OTHERWISE SPECIFIED TOLERANCES		MYOUNG 美阳 www.meiyangdz.com			
DECIMALS: X : ±*** X.X : ±*** X.XX : ±*** X.XXX : ±***	ANGLES: X : ±*** X.X : ±***	DSND	YangFeng	DATE	2022-06-06
		CHKD	ZhouRuicai	DATE	2022-06-06
		APVD	XueShun Yong	DATE	2022-06-06
WEIGHT:		SCALE:	SIZE: A4	VIEW:	⊙ ⊚
SHEET 1 OF 1		UNIT: mm	REV.: A/0	OBJECT: MY	TITLE: 电池扣CR2050-D DIP 卷装
				PART NO.:	MY-2050-01-R
				DRAW NO.:	MY-BD-0056