

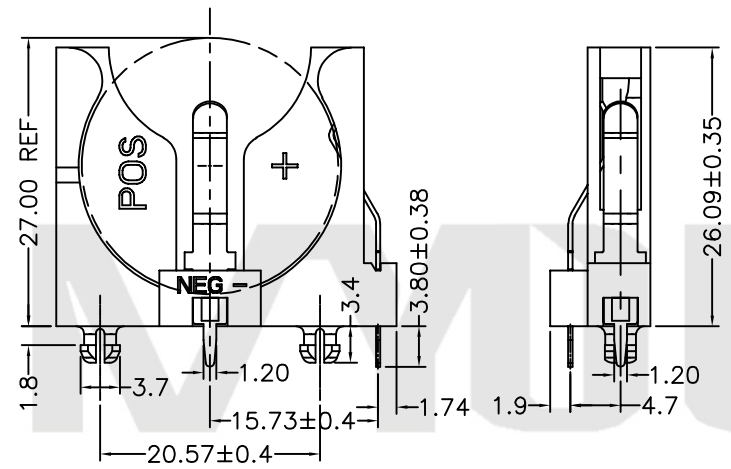

REV.	ECN NO.	REVISED	DATE

NOTE:

- 1.MATERIAL:
a.HOUSING:PBT UL94V-0 BLACK
b.CONTACT: STAINLESS STEEL
(SURFACE PLATING: Sn-PLATING)
SEE ORDERING INFORMATION
- 2.ELECTRIC:
a.CONTACT RESISTANCE: 100 MILLIOHMS MAX
b.INSULATION RESISTANCE: 100 MEGA OHMS MIN
c.DIELECTNIC VOLTAGE: 500V AC ONE SEC LEVEL
d.OPERATING TEMPERATURE: -25°C ~ +85°C

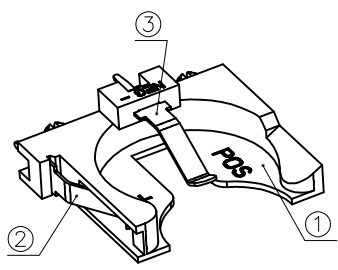
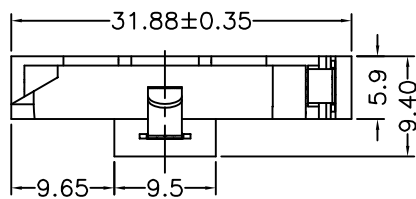

ORDERING INFORMATION

BS-24-A1AK026

PLATING:
A-Au1U"
C-NiSn
J-Ni100U"~120U"
K-Sn

MATERIAL:
1A-PBT BLACK
1B-PA66 BLACK
2A-PPA BROWN
2B-PPA BLACK
3A-PPS BROWN
3B-PPS BLACK
4A-LCP WHITE
4B-LCP BLACK
5B-PA10T BLACK

电池座系列
BS-24系列
DIP 90° TYPE

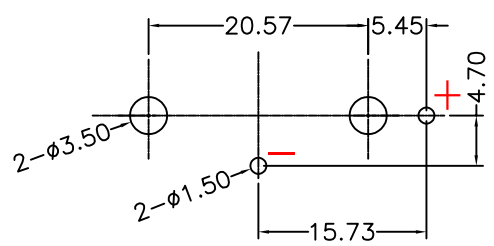

PCB Layout Diagram
Top View

工程部
2022-10-24
H. WANG

3	TERMINAL(-)	1	Stainless Steel,T=0.4mm	Sn-Plating
2	TERMINAL(+)	1	Stainless Steel,T=0.4mm	Sn-Plating
1	HOUSING	1	PBT	BLACK
NO.	PART NAME	Q'TY	MATERIAL	PLATING & COLOR

UNLESS OTHERWISE SPECIFIED TOLERANCES		MYOUNG 美阳 www.meiyangdz.com	
DECIMALS: X :±0.30 X.X :±0.25 X.XX :±0.20 X.XXX :±0.10	ANGLES: X :±1° X.X :±0.5°	DSND YangFeng	DATE 2022-10-24
		CHKD ZhouRuicai	DATE 2022-10-24
		APVD XueShun Yong	DATE 2022-10-24
WEIGHT:2.71g		SCALE: 2:1	SIZE: A4
SHEET 1 OF 1		VIEW:	
		UNIT: mm	REV.: A/0
		OBJECT: MY	DRAW NO.:WD-CP-0247